

BF60

60 hp 4-stroke Outboard Engine

Light and compact

A mere 110kg makes the BF60 one of the lightest in its class.

Honda 4-stroke engine

60 hp water-cooled, 4-stroke OHC engine is quiet, with low fuel consumption and emissions.



Boosted Low Speed Torque (BLAST™) System advances ignition timing during full-throttle acceleration, resulting in explosive hole shot torque.



Adjusts air/fuel mixture and ignition according to demands, maximising power and fuel efficiency when cruising.

Optional power thrust

Power thrust model available (BFP60) offering a gear ratio of 2.33:1 opposed to the standard 2.07:1 ratio provides optimum performance for heavier craft.

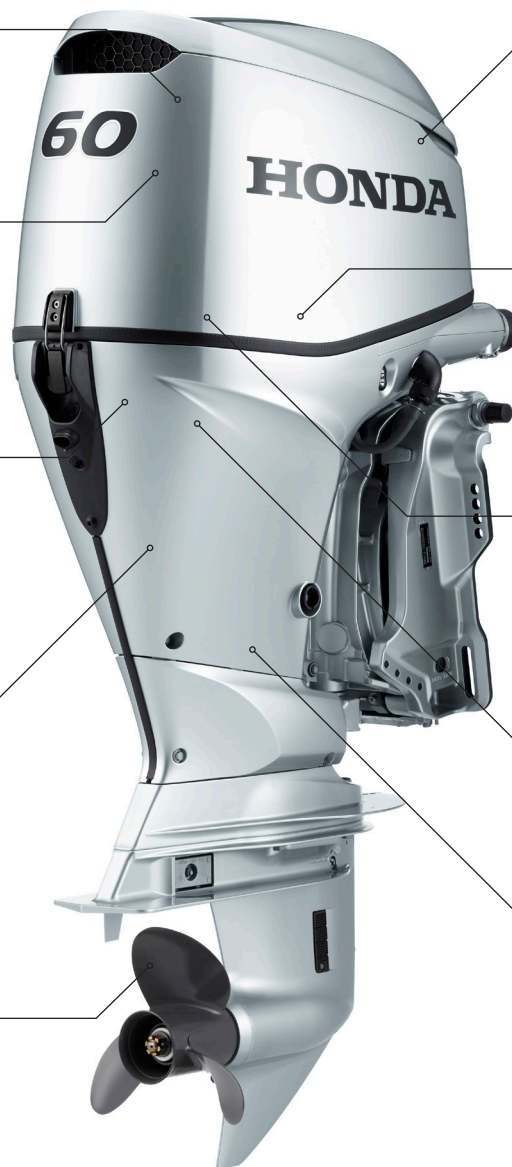

Programmed fuel injection

PGM-FI multi-port fuel injection delivers class-leading fuel economy.

Variable speed trolling

The user can control the trolling range of 750–1,000RPM via adjustable 50 RPM increments via a remote dash switch.



This allows users to connect the engine to an ever increasing variety of electronic equipment such as chart plotters, fish finders and navigation equipment.

New Design

New wedge shape design provides streamlined appearance.

Easy to manoeuvre

The engine can be turned through a wider angle to allow for a tighter turning circle, ideal when docking

The new streamline BF60 is one of the lightest and most compact 4-stroke engines in its class, offering tremendous manoeuvrability. Honda's innovative BLAST system offers explosive low speed acceleration and trolling is made easier than ever when in port with the new incremental speed controls. The unique ECOMo feature means the engine is cleaner, quieter and fuel consumption has been reduced significantly.

Price
(incl. VAT)



Domestic Use

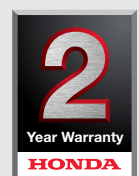

Professional Use

*6 Year Warranty subject to following the service schedule